

Weldcraft™ W-280

Formerly WP-280

Hand-Held Water-Cooled
TIG Welding Torches



QUICK SPECS

Model

W-280 Super Cool

Applications

Aerospace	Pipe and tube fabrication
Aluminum fabrication	Precision metal fabrication
Aluminum ship repair	Pressure vessel fabrication
Automotive	Shipbuilding
Exotic material fabrication	Tool and die
Manufacturing	Tube and pipe
Maintenance and repair	Vocational

Rated Output DC: 280 A, AC: 195 A

Duty Cycle 100%

Electrode Range .020–1/8 in. (0.5–3.2 mm)

W-280 Super Cool™ TIG torch

Formerly known as the WP-280, the W-280 Super Cool is a reliable water-cooled torch designed for demanding, high-amperage applications. The W-280 Super Cool is engineered with innovative technology and welding efficiency in mind.

Super Cool technology provides additional surface area to increase cooling efficiency and capacity.

Reduce downtime due to overheating through consistent water-cooled performance.

Extend torch life with dependable water-cooled technology.

Reduce leakage of gas and water through secure mechanical fittings and connections.

Note: Torches delivered may vary slightly from images shown.

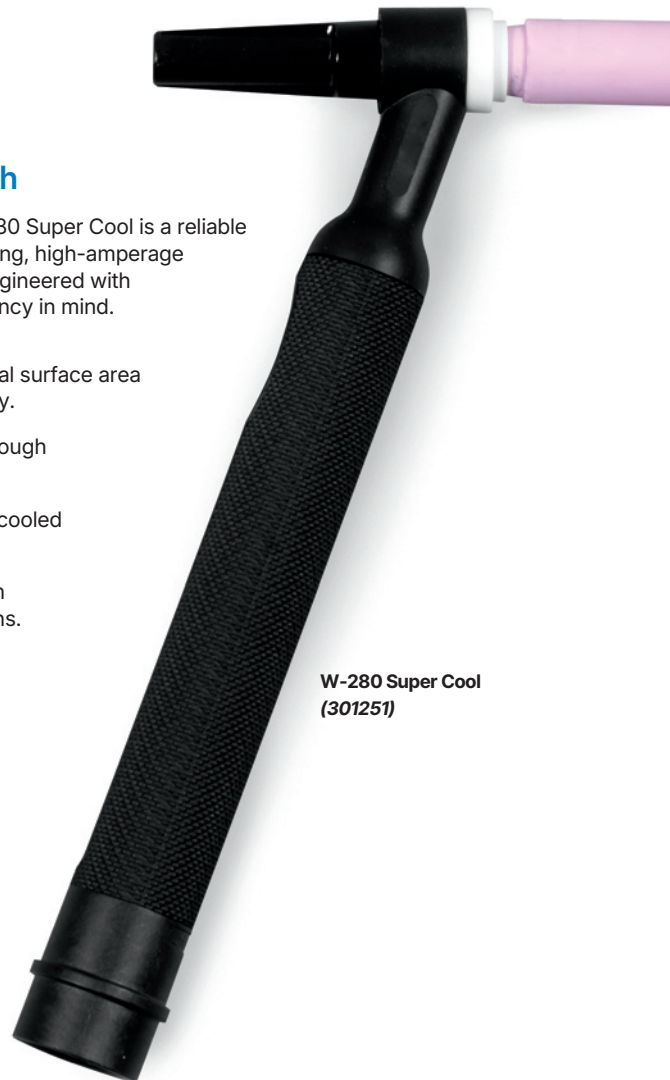

W-280 Super Cool
(301251)



Miller Electric Mfg. LLC
An ITW Welding Company
1635 West Spencer Street
P.O. Box 1079
Appleton, WI 54912-1079 USA

Equipment Sales US and Canada
Phone: 866-931-9730
International Phone: 920-735-4554

MillerWelds.com



Torch Packages

MODEL		BRAIDED RUBBER		BRAIDED RUBBER WITH 50 MM DINSE
Old Model	New Name	12.5 ft. (3.8 m)	25 ft. (7.6 m)	25 ft. (7.6 m)
WP-280	W-200 Super Cool™	301251012	301251025	301251001*

Torch packages include torch body, handle, power cable, gas hose, water hose, and long back cap.

*Cable cover included.

Connectors

1-piece power cable connectors



195377
50 mm Dinse-style with water return line for water-cooled torch.



301884
50 mm Dinse-style connector that adapts machines with flow through gas valves to coolers.



225028
50 mm thread-lock-style for water-cooled torch.



45V11
Power cable adapter for water-cooled torch.

MACHINES	CONNECTION TYPE	1-PIECE POWER CABLE CONNECTORS
TIG Machines		
CST™ 280/282	50 mm Dinse-style	195377
Dynasty® 200/210/280/300/350/400	50 mm Dinse-style	195377
Dynasty® 700/800	50 mm thread-lock	225028
Maxstar® 200/210/280/350/400	50 mm Dinse-style	195377
Maxstar® 700/800	50 mm thread-lock	225028
Syncrowave® 200/210/212	50 mm Dinse-style gas thru	301884
Syncrowave® 250 DX/300/350 LX/400	50 mm Dinse-style	195377
	1/2 in. stud	45V11
Multiprocess Machines		
Dimension™ 302/452/NT 450/650/652	1/2 in. stud	45V11
Dynasty® 280 DX Multiprocess/300 Multiprocess	50 mm Dinse-style	195377
Multimatic® 235/255	50 mm Dinse-style	195377
PipeWorx	1/2 in. stud	45V11
XMT® 304/350/400	50 mm Dinse-style	195377
XMT® 450/650	1/2 in. stud	45V11
Engine-Driven Machines		
Most Big Blue®, Trailblazer®, Bobcat™, Blue Star® and Wildcat® models	1/2 in. stud	45V11
Big Blue® 450 Duo CST	50 mm Dinse-style	195377
Other Adapter		
	Stud to Dinse-style adapter	232728

Consumables (Refer to Owner's Manual for additional replacement parts.)

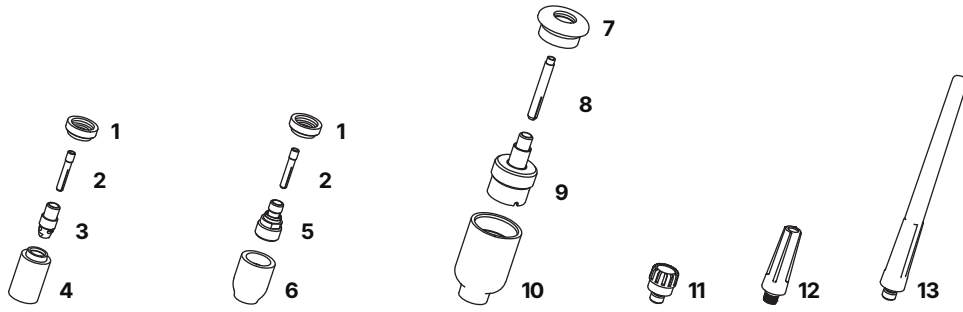

NON-GAS LENS									
Electrode Size — inch (mm)	.040 (1.0)			1/16 (1.6)			3/32 (2.4)		1/8 (3.2)
1 Insulator (required)	598882			598882			598882		598882
2 Collet	13N21			13N22			13N23		13N24
3 Collet Body	13N26			13N27			13N28		13N29
Nozzle Size — size # (inch)	3 (3/16)	4 (1/4)	5 (5/16)	6 (3/8)	7 (7/16)	8 (1/2)	10 (5/8)	12 (3/4)	Short
4 Alumina	—	13N08	13N09	13N10	13N11	13N12	13N13	—	—
* Lava	—	13N14	13N15	13N16	13N17	13N18	13N19	—	—
* Long Lava	796F70	796F71	796F72	796F73	—	—	—	—	—
* X-Long Lava	796F74	796F75	796F76	796F77	—	—	—	—	—
GAS LENS									
Electrode Size — inch (mm)	.040 (1.0)			1/16 (1.6)			3/32 (2.4)		1/8 (3.2)
1 Insulator (required)	598882			598882			598882		598882
2 Collet	13N21			13N22			13N23		13N24
5 Gas Lens	45V42			45V43			45V44		45V45
Nozzle Size — size # (inch)	3 (3/16)	4 (1/4)	5 (5/16)	6 (3/8)	7 (7/16)	8 (1/2)	10 (5/8)	12 (3/4)	Short
6 Alumina Gas Lens	—	53N58	53N59	53N60	53N61	53N61S	—	—	—
LARGE DIAMETER GAS LENS									
Electrode Size — inch (mm)	.040 (1.0)			1/16 (1.6)			3/32 (2.4)		1/8 (3.2)
7 Insulator (required)	54N63-20			54N63-20			54N63-20		54N63-20
8 Collet	13N21L			13N22L			13N23L		13N24L
9 Large Diameter Gas Lens	45V0204S			45V116S			45V64S		995795S
Nozzle Size — size # (inch)	3 (3/16)	4 (1/4)	5 (5/16)	6 (3/8)	7 (7/16)	8 (1/2)	10 (5/8)	12 (3/4)	Short
10 Large Diameter Gas Lens	—	—	—	57N75	—	57N74	53N88	53N87	53N89
* Large Diameter Gas Lens-L	—	—	—	57N75L	—	57N74L	53N88L	53N87L	—
* Large Diameter Gas Lens-XL	—	—	—	57N75XL	—	57N74XL	53N88XL	53N87XL	—
BACK CAPS									
11 Short 41V33	12 Medium 41V35	13 Long 41V24	* Back cap insulator 9-4						

*Not shown.

Tungsten

Tungsten for the most demanding TIG welding applications!

Available in four types and industry-standard diameters, our line of Weldcraft™ tungsten electrodes has undergone rigorous testing to ensure the highest quality and durability. Color-coded packages include ten 7-inch (175 mm) tungsten electrodes.

Note: Refer to manufacturer SDS sheets for proper preparation and safety. Use proper ventilation/capture during preparation. Refer to manufacturer warning regarding ventilation.



Type	Diameter in. (mm)	Part #	
2% Ceriated (EWCe-2)			
Performs well in DC welding and arc starting at low-current settings, and offers excellent performance in AC processes.	0.040 (1.0)	WC040X7	
	1/16 (1.6)	WC116X7	
	3/32 (2.4)	WC332X7	
	1/8 (3.2)	WC018X7	
Provides excellent arc starting, arc stability and re-ignition, and less tip erosion in AC or DC welding. Can substitute for 2% Thoriated.	5/32 (4.0)	WC532X7	
	2% Lanthanated (EWLa-2)		
	0.040 (1.0)	WL2040X7	
	1/16 (1.6)	WL2116X7	
Forms a clean, balled end when heated and provides good arc stability for AC welding with a balanced or unbalanced squarewave or sine wave.	3/32 (2.4)	WL2332X7	
	1/8 (3.2)	WL2018X7	
	5/32 (4.0)	WL2532X7	
	Pure (EWP)		
Combines the best of all alloying elements, and provides excellent arc stability in AC or DC welding.	0.040 (1.0)	—	
	1/16 (1.6)	WP116X7	
	3/32 (2.4)	WP332X7	
	1/8 (3.2)	WP018X7	
Rare Earth (EWG)	5/32 (4.0)	—	
	0.040 (1.0)	—	
	1/16 (1.6)	WG116X7	
	3/32 (2.4)	WG332X7	
Pure (EWP)	1/8 (3.2)	WG018X7	
	5/32 (4.0)	—	

Replacement Parts

Torch Body		
W-280		301251
Handle		
Knurled		269335
Braided Rubber Power Cables and Hoses		
	12.5 ft. (3.8 m)	25 ft. (7.6 m)
Power Cable	269757	269758
Water Hose	269766	269767
Gas Hose	—	269771

Genuine Miller® Accessories



Gas Lens Kit AK4GL

Includes one short back cap, one of each size (#6, #7, #8) alumina nozzle, and one of each size (1/16, 3/32, 1/8 inch) of the following: gas lens, collet, and 7-inch 2% ceriated tungsten electrode.



Gas Lens Kit 301877

For use with Syncrowave® 212. Consumables match Auto-Set recommendations.

Includes one of each size (#5, #8) alumina nozzle, and one of each size (1/16, 3/32 inch) of the following: gas lens, collet, and 7-inch 2% ceriated tungsten electrode.



Accessory Kit AK4C

Includes one long back cap, one of each size (#5, #6, #7) alumina nozzle, and one of each size (1/16, 3/32, 1/8 inch) of the following: collet, collet body, and 7-inch 2% ceriated tungsten electrode.

Extension Kit

EK-1-25-R 25 ft. (7.6 m), rubber

Cable Covers

WC0183 11.75 ft. (3.6 m)

For use with torch package 301251012.

WC0182 24.25 ft. (7.4 m)

For use with torch packages 301251025 and 301251001.



Wireless Remote Foot Control 301580

For remote current and contactor control. Receiver plugs directly into the 14-pin receptacle of Miller machine.

90-foot (27.4 m) operating range.



Wireless Remote Hand Control 301582

For remote current and contactor control. Receiver plugs directly into the 14-pin receptacle of Miller machine. 300-foot (91.4 m) operating range.



RCC-14 Remote

Contactor and Current Control 151086

East/west rotary-motion fingertip control attaches to TIG torch using two hook-and-loop fasteners. Includes 26.5-foot (8 m) cord with 14-pin plug.



RCCS-14 Remote

Contactor and Current Control 043688

North/south rotary-motion fingertip control attaches to TIG torch using two hook-and-loop fasteners. Includes 26.5-foot (8 m) cord with 14-pin plug.



Low-Conductivity TIG Coolant 043810

Must be ordered in quantities of four. One-gallon recyclable plastic bottle. Miller coolants contains a base of ethylene

glycol and deionized water to protect against freezing to -37° Fahrenheit (-38°C) or boiling to 227° Fahrenheit (108°C).

Distributed by:

